

Ultra®-2 HP Manual Fill

Height: 31.9" (81.0cm) Width: 16.0" (40.6cm) Depth: 26.2" (66.5cm)



- Full 2-year parts and 1-year labor warranty. 5-year parts and 1-year labor warranty on compressor and 3-year parts and labor warranty on electronics. See the product manual for additional details.
- Large 3gal (11.4L) hopper for optimum cooling and serving capacity
- Refrigeration system internally monitored to ensure long lasting performance
- Reversing auger design quickens freeze time and reduces air mixing
- User interface communicates need for cleaning and maintenance: simple programming, cleaning and preventive maintenance guides ensure reliable operation and performance – minimizing down time and maximizing serving capacity and profits

Agency:



Specifications

Product #: 34000.6080

Refrigerant: R452A

Water Access: Not Plumbed

Handle: Extended Handle

Finish: Black

Hoppers: Two

Additional Features

Electrical & Capacity

Volts*	Amps	Watts	Cord Attached	Plug Type	8oz cups/hr 236ml cups/hr	Input H ² O Temp.	Phase	# Wires plus Ground	Hertz
120	12	1440	Yes	NEMA 5-15P	-	60°F (15.5°C)	1	2	60

*When a BUNN is machine rated 120/208-240V, 120/208V or 120/240V, the higher voltage is the supply voltage needed to power the machine. The 120V is there to supply power to some components rated 120V in the machine, but it is not the supply voltage and would not power the machine if the machine is marked with the before mentioned ratings.

Plumbing Requirements

PSI	kPa	Fitting Supplied	Water Flow Required (GPM)
-	-	-	-

CAD Drawings

2D	Revit	KLC
●		

WARNING:



BUNN® reserves the right to change specifications and product design without notice. Such revisions do not entitle the buyer to corresponding changes, improvements, additions or replacements for previously purchased equipment. For most current specifications and other info visit bunn.com.

Last Updated:
04/26/2023

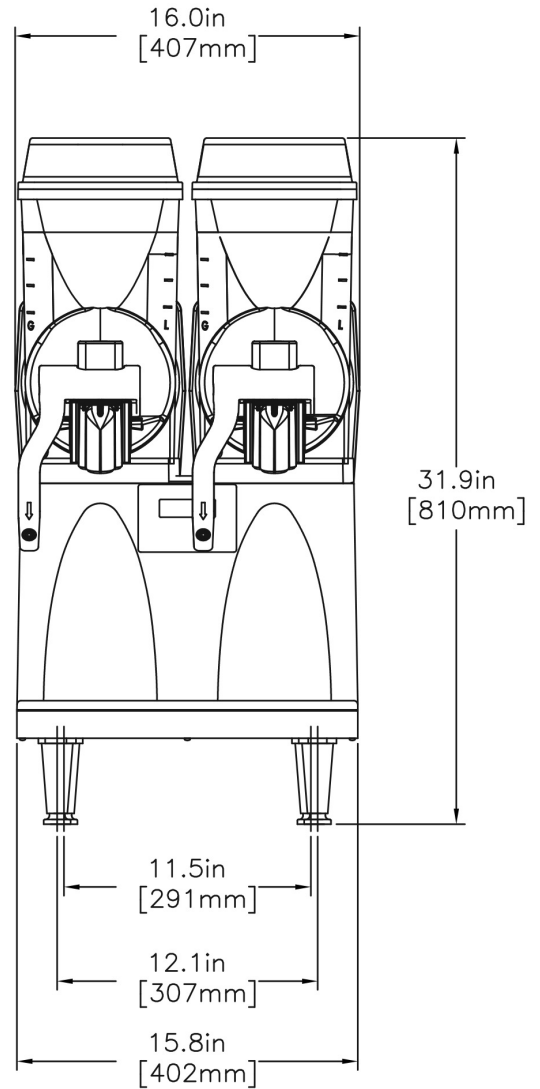
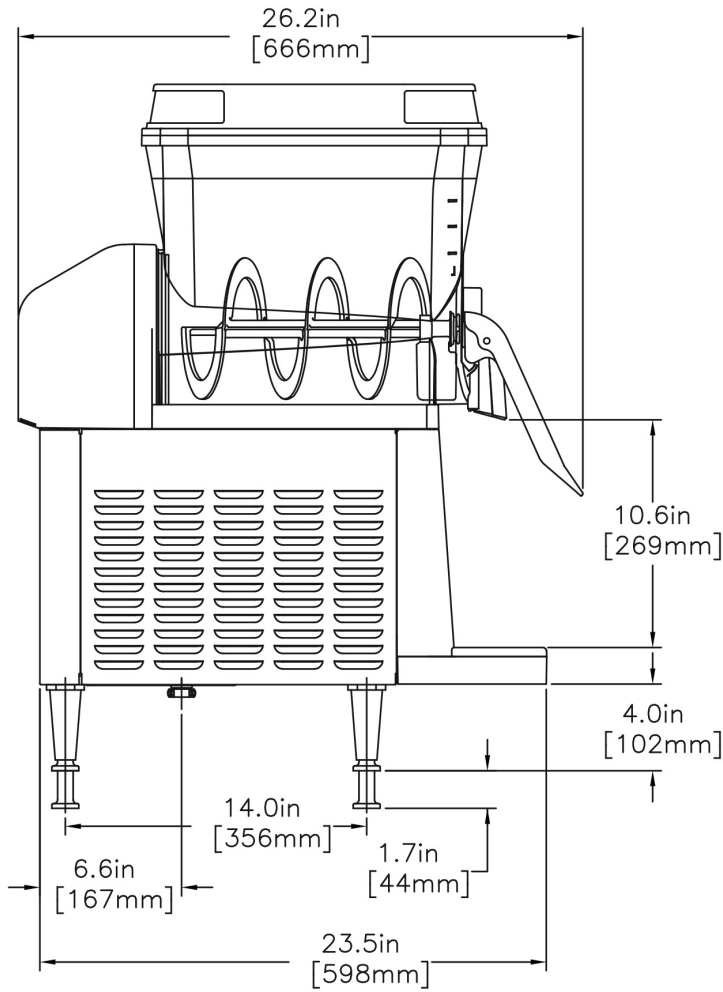
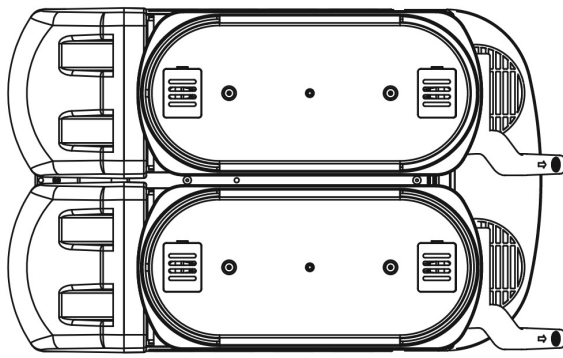

	Unit			Shipping				
	Height	Width	Depth	Height	Width	Depth	Weight	Volume
English	31.9 in.	16.0 in.	26.2 in.	28.7 in.	19.1 in.	24.6 in.	-	7.819 ft ³
Metric	81.0 cm	40.6 cm	66.5 cm	72.9 cm	48.6 cm	62.5 cm	-	0.221 m ³



BUNN® reserves the right to change specifications and product design without notice. Such revisions do not entitle the buyer to corresponding changes, improvements, additions or replacements for previously purchased equipment. For most current specifications and other info visit bunn.com.

Last Updated:
04/26/2023

Related Products & Accessories: Ultra®-2 HP Manual Fill(34000.6080)



DRIP TRAY ASSY,
LOWER-BLK

Product #: 28086.0001

COVER, DRIP TRAY
ULTRA 2 BLK

Product #: 32068.0001

ULTRA LAF KIT,SEP
WATER LINES

Product #: 37960.0000

KIT, CFV UPGRADE W/
HPRS ULTRA-2 BLK .035

Product #: 44071.0101



BUNN® reserves the right to change specifications and product design without notice. Such revisions do not entitle the buyer to corresponding changes, improvements, additions or replacements for previously purchased equipment. For most current specifications and other info visit bunn.com.

Last Updated:
04/26/2023

Serving & Holding Options: Ultra®-2 HP Manual Fill(34000.6080)

Serving and Holding selections are currently unavailable. Please contact your sales representative to find out more information.



BUNN® reserves the right to change specifications and product design without notice. Such revisions do not entitle the buyer to corresponding changes, improvements, additions or replacements for previously purchased equipment. For most current specifications and other info visit bunn.com.

Last Updated:
04/26/2023